

SOME BFM STOVE VARIANTS



portway

S T O V E S

SOLID FUEL HEATING STOVES MULTI-FUEL MODELS

INSTALLATION AND OPERATING INSTRUCTIONS

LEAVE THIS DOCUMENT WITH THE HOUSEHOLDER!



All BFM Stoves exceed the safety and performance requirements of European Standards Intermittent burning solid fuel roomheaters for installation with a single dedicated chimney. Independent thermal and emissions testing by SGS Environmental BV, Arnhem, Notified Body No 0608 - July 2009

	BFM No1		BFM No2		BFM No3		BFM Inset		
	Wood (Beech)	Mineral Fuel (Anthracite)	Wood (Beech)	Mineral Fuel (Anthracite)	Wood (Beech)	Mineral Fuel (Anthracite)	Wood (Beech)	Mineral Fuel (Anthracite)	
Test Standard	EN 13240:2001+A2 2004						EN13229: 2001		
Test Cycle	1.15kg over 0.75hrs	0.76kg over 1.1hrs	1.51kg over 0.72hrs	1.05kg over 1.0hrs	2.15kg over 0.73hrs	1.65kg over 1.01 hrs	1.06kg over 0.82hrs	0.74kg over 1.01 hrs	
Settings	Primary 0, 2nd 25mm	Primary 30, 2nd 25mm	Primary 0, 2nd 25mm	Primary 35, 2nd 20mm	Primary 0, 2nd 25mm	Primary 45, 2nd 25mm	Primary 5, 2nd 30mm	Primary 32, 2nd 20mm	
Flue Draught Pa (ins WG)	12 (0.05)	12 (0.05)	12 (0.05)	12 (0.05)	12 (0.05)	12 (0.05)	12 (0.05)	12 (0.05)	
Efficiency %	78.8	78.2	78.2	77.3	76.3	69.4	76.5	75.5	
Recommended Output Rating kW	4.9	4.9	6.9	6.9	9	9	4.7	4.7	
Output when fitted with reducer brick pair, kW	3.0	3.0	5.0	5.0	7.1	7.1	2.9	2.9	
Mean Flue Gas Temp Rise °C	226	216	280	292	297	358	237	273	
Minimum air entry requirement	2700 mm ²		3800 mm ²		4900 mm ²		2700 mm ²		
Minimum Clearance to combustibles (allow min 50mm clearance to non-combustibles)	350mm		300mm		300mm		In masonry fireplace to BS1251, 150mm at sides 350mm above		
	With 150mm or longer legs or base fitted, or with the optional heat shields, hearth temperature is <100°C – A light duty hearth may be used.								
Emissions as if 02=13%	NOx mg/m ³	44	-	77	-	55	-	66	-
	CO %	0.19	0.10	0.14	0.08	0.19	0.08	0.35	0.08
	CxHy mg/m ³	169	-	94	-	205	-	761	-
	Gas flow g/sec	4.6	5.4	5.4	6.1	7.3	10.0	4.6	5.0
	Smoke Emission mg/m ³	38	21	74	36	135	21	78	14

Glyn Hughes

I declare that this information is true, these products meet the requirements of Harmonised Standards and are fit for sale. Signed on behalf of the manufacturer by Glyn Hughes, Design Engineer, at Winster, Derbyshire, England 28. Nov. 2017

Read these instructions! Use only recommended fuels!

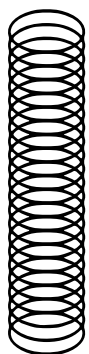

This document, when completed by the installer, constitutes part of a 'Hearth Notice' for purposes of Building Law. It must be left with the householder and placed where it can easily be found.

INSTALLED AT LOCATION:

BY:

EMERGENCY CONTACT:

I definitively assert that this installation is safe, has been lit and demonstrated to the householder, conforms with current building regulations and with these instructions

SIGNED:

DATE:

Flue Draught measured on commissioning:

Pa
WG

Fuel used on commissioning

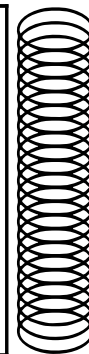

FOR A QUALIFIED INSTALLER, FUEL SUPPLIER or CHIMNEY SWEEP:
UK: The Solid Fuel Association, 7 Swanwick Court, Alfreton, Derbyshire DE55 7AS Tel:0845-601-4406 www.solidfuel.co.uk
Rol: Irish Nationwide Fireplace Organisation, 162 Capel Street, Dublin 1 Tel:01-801-5959 www.fireplace.ie

PRODUCTION NUMBER

BFM 1, 2, 3 and Inset stoves may be used in smoke control areas when operated strictly in accordance with these instructions and with Soliftec Smoke Advice Sheet No1 (www.soliftec.com/smokeadvice.htm), when burning:
UK: Untreated wood logs or authorised smokeless fuels (*Exempted from s20 of the Clean Air Act 1993*) **Rol:** Wood logs, smokeless fuels or peat briquettes, but not petroleum coke (*Control of Atmospheric Pollution Regulations, 1970*)



IN 1830 Charles Portway built a stove to heat his ironmongery shop at Halstead in Essex. It was so good that his neighbours started asking for them. Mr Portway had done something completely new - designed his stoves right from the start to give out the maximum heat from the minimum fuel, so that he is known as **"The Founding Father of Energy Efficiency"**. The stoves that bear his name are still made in Britain by the direct successors of the company he established.

THIS APPLIANCE BECOMES EXTREMELY HOT AND CAN PRODUCE POISONOUS GASES.

A fire-guard should be used if children or the infirm are present. The installer is required to **EXACTLY** follow these instructions and to completely comply with all local, national and international standards.

Building regulations are available at www.soliftec.com

INSTALLING a stove is a 'controlled service', the law expects that it is either supervised by a qualified installer or that the building inspector is informed. Check with your local authority.

ASBESTOS: Your stove does not contain asbestos, but take care to avoid disturbing asbestos in an old installation.

WEIGHT: Your stove is heavy - take great care when moving it and ensure that the intended fireplace can support the weight- consider fitting a load distributing plate.

YOUR CHIMNEY, by becoming warm, makes the gas inside it rise, pulling fresh air into the stove to make it work. It must:

- Generate a draught in use of at least 12Pa (0.05ins wg)
- Be capable of withstanding the temperatures generated.
- Be absolutely incapable of leaking fumes into the dwelling
- This may commonly be achieved by it:
 - Being at least 5m high.
 - Terminating at least 1m above any roof ridge.
 - Having an internal cross-section equivalent to not less than 125mm diameter for No1, No2 and Inset models, 150mm dia for No3, and never more than 0.14m² (eg 375 x 375mm)
 - Being free from even the slightest crack or source of leakage.
 - Having no bends sharper than 45°.

- Being swept and entirely free of obstructions
- Being connected only to this one appliance.
- Being of thick masonry or otherwise adequately insulated.
- Conforming to local building regulations.

Special rules apply where the flue passes through timber, thatch or other vulnerable materials- take specialist advice.

Although it is possible to access the chimney through the fire with the throat plate removed, fit hatches to provide access if needed.

YOUR FIREPLACE: Stoves become VERY hot, the installer must specify a fireplace which will completely protect the building against fire. A masonry hearth >100mm thick (>10mm thick where raised base fitted) extending at least 250mm in front of the stove, 100mm at the sides is likely to suffice, but other configurations are possible at the discretion of the expert installer. Even beyond the safety clearances given on the front page items can still become very hot - take great care in siting wax, paper etc.

AIR SUPPLY: Your stove needs air to breathe - there must be a permanent fresh air supply into the space in which it is installed equal to 550mm² for each kW of output. This can often be provided by air leaking around door frames etc. (it is commonly accepted that this alone may suffice for appliances <c.5kW) but in any case of doubt, fit a purpose-made air vent. An extractor fan, or another fuel-using appliance in the same building, can remove this air.

The Safe Air Supply kit, available as an extra, provides the correct fresh air for combustion and ventilation via a flexible tube from outside, without draughts across the room and meets the complete requirements of UK and RoI Building Regulations

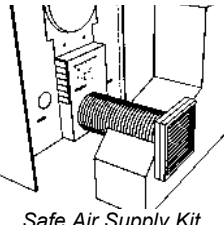

Safe Air Supply Kit

FITTING

FREE-STANDING MODELS Fasten the flue outlet and blanking plate to the top or back flue outlet. Your stove can be sealed to the chimney using a **short** length of uninsulated pipe (125mm for No1 & 2, 150mm for No3) in several ways, four of which are shown.

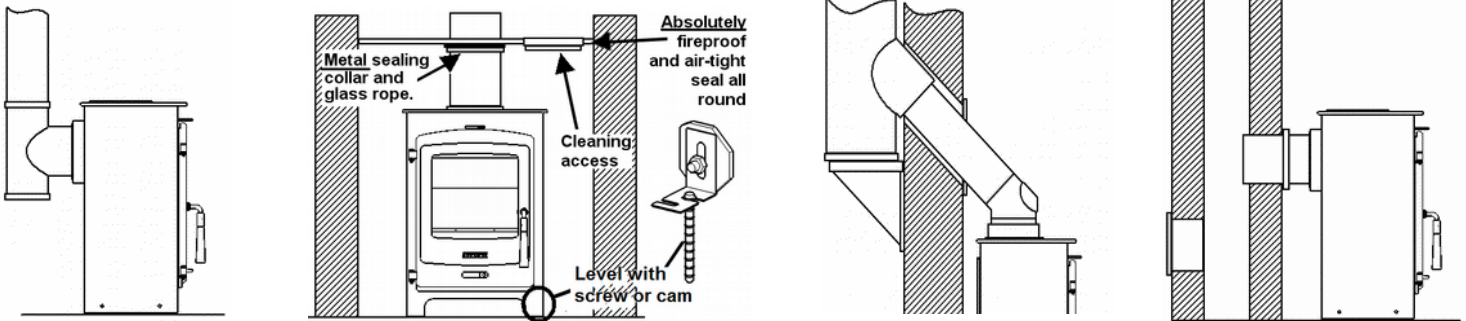

Rear outlet to top outlet by 'T' piece with cleaning door- the preferred method.

Through **steel or concrete** closure plate (with cleaning door) into old, oversized, chimney. Steel sealing collar.

45° top outlet sleeved through wall into external insulated flue. Cleaning hatches on bends.

Rear connection into chimney with sealing collar. Cleaning door on opposite side.

INSET MODELS Fix the soft seal to the back seating surface of the stove. Pull off the top and push stove into opening. Screw to the masonry of the fireplace at the two points arrowed and proceed with the fix as shown below. Inset stoves deliver **very** hot air into the room, so that the 350mm clearance above to combustible materials must be strictly observed.

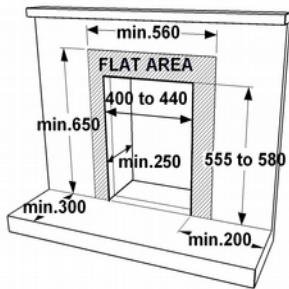

Suitable masonry fireplace, dimensions in millimetres.

'FIREPLACE SEAL' METHOD: Fix the stove and, through the flue outlet, fill any gap behind with vermiculite granules topped with mortar. Carefully check that the fire has an absolutely airtight seal against the fireplace.

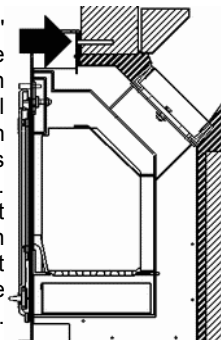

'CHIMNEY SEAL' METHOD:

Remove the round connector. Fit the flue pipe, or flexible liner with a 150mm adaptor, into the chimney and seal its loose end to the round connector with fire cement. Fix the stove. Bolt the connector and pipe back in place from inside. Check that the pipe forms a clear route from stove to chimney terminal with no leaks into the masonry space.

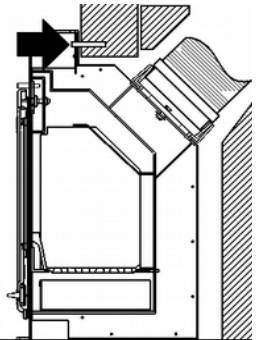

Whichever model and method is used it is **imperative** that: (1) The route for gases from the stove to the chimney terminal is **completely** airtight; even the tiniest gap or crack can spoil the updraught. Seal all joints with fireproof cement and/or heatproof rope. (2) It is possible to sweep the entire length- access doors may be required. (3) The entire construction is of durable fireproof materials. (4) **Fit a CO alarm.**

CHECK THE INSTALLATION !

Once installed, light the fire, demonstrate it to the householder and check that:

- 1) It burns controllably and does not emit fumes to the room
- 2) The route for gases from the stove to the chimney terminal is completely airtight, unobstructed and able to be swept.
- 3) The entire construction is of durable fireproof materials.
- 4) The flue presents a draught in use of at least 12Pa

LIVING WITH YOUR STOVE

Every fuel, chimney and condition of use is different. Only experience will show which are the best settings for you.

LIGHTING If lighting after a period of non-use, do check that the flueways and chimney are completely clear. Empty the ashes. Place two or three firelighters close together, or screwed-up paper covered with dry sticks, at the back of the grate and light them. When they are burning well gently fill the fire with dry fuel, close the door and set the air controls to the 'high' (open) position. When the fire is burning well, move the controls to the lowest practical setting.

FILLING: Don't fill above the level shown in the diagram.

CONTROL How fast the fire burns depends on how much air reaches the fuel. The stove has two air controls, one below the window ('primary'(1)) and one above ('airwash control'(2)). Move the slides to the right for

highest output, to the left for 'low'. They can get very hot, so move them only with the handle supplied.

Our tests indicate highest efficiency on wood with the primary (1) control all but closed and the airwash (2) at 2/3 open. Anthracite works best with the airwash closed down and the primary 1/3 open. The best settings will depend on your fuel, air supply and flue draught and can only be found from experience.

SMOKE STOPS To make sure your stove always receives enough air to burn away the smoke produced when using wood, 'Smoke Stops' are fitted to prevent the air controls from being fully closed. If, and only if, smoke is not a concern you may unscrew and remove the stops. Controllability and burn times will be improved, but more smoke may be emitted. **The stops must always be in place when burning wood in smoke control areas of the United Kingdom.**

(Stops are built-in on 'Dalton' models and cannot be removed)

EMPTYING ASHES use the tool or glove to open the door and stir the fire with a poker. Or agitate the firebed by using the tool to operate the riddling mechanism on the right-hand side of models where this fitted. Use the angled ashpan tool to lift out the ashpan. Remember to let ash cool before disposing in plastic sacks or dustbins. There is no need to empty every last speck, but ash from mineral fuels should never be allowed to build up so that it comes into contact with the underside of the grate.

EXTENDED BURNING Allow the fire to burn down to a low, hot firebed. Empty the ash and fully fill with hard fuel such as anthracite (c30mm size is best). Set the air control to 'low' and your stove can burn for up to ten hours without attention.

KEEPING THE WINDOW CLEAN Reduce the risk of staining by using only very dry fuel and keeping the airwash control slightly open. Simply operating the stove for a few minutes at high output will often burn-off any deposits left by tarry or wet fuels. Severe stains can be removed when cold with a domestic bleach cleaner. The window is not glass but a transparent ceramic, it may develop tiny hairline cracks, these are harmless, and a characteristic of the toughest and most heat-resistant material known.

OPENING THE DOOR This stove is designed to be operated only with the door closed. Open the door very slowly to minimise fume emission and prevent hot fuel falling out. Remember that the whole stove becomes extremely hot.

SUMMER SHUT DOWN: Before a long period of non-use, empty fuel

and ash, remove the throat plate and leave all the air controls open to allow ventilation to reduce condensation.

FUELS

There is no 'perfect' fuel, so we strongly recommend that you try a selection of fuels (or mixtures) to find which suits you best.

SMOKE CONTROL: In certain areas special rules apply to reduce smoke nuisance. Check with your local authority.

WOOD only emits as much carbon to the atmosphere as the tree took in when growing, so wood is considered the 'carbon neutral' fuel. When wood is cut down its cells are full of water. Burning such wet or 'green' wood wastes heat in making steam and produces flammable, acidic tars which will cling to, and rapidly damage, your stove and chimney. Split logs will typically take two years to become reasonably dry, round logs very much longer. Cracks in the ends, a hollow sound when tapped and bark falling away are all signs that a log may be ready for use. The fine, white residue produced when wood burns is not ash, but the remains of cell walls which can burn if kept hot enough, so don't de-ash the fire until absolutely necessary when using wood.

For best performance, and *always* for low smoke emission:

Split logs lengthways for drying

- Use logs no bigger than about 100mm x 250mm
- Ensure logs are absolutely dry (less than 20% moisture)
- Fill the stove criss-cross, so air can circulate between logs.
- Fill 'little and often'
- Always have the airwash control (2) at least a little open.
- When first lighting, or reviving a fire from embers, use only very small, thin, dry, sticks.

JOINERY WASTE Dry wood offcuts will burn well, but don't expect softwood waste to burn as cleanly or for as long as hardwood logs.

PEAT: Sod turf must be thoroughly dry.

LIGNITE (not smokeless) is a natural mineral, between peat and coal. It lights easily and burns well, but produces much ash

ANTHRACITE (Smokeless) is a natural hard, shiny form of coal. Slow to light, it can burn for very long periods with great heat. Despite its high price-per-bag it generally works out to be one of the cheapest of all fuels. Use the 'small nuts' size.

COKE (Smokeless) is coal from which the smoke has been removed. Sometimes difficult to light, it burns very cleanly.

BRIQUETTES Are compressed blocks of fuel, generally able to burn for long periods and remarkable for their consistency. 'Homefire' and 'Phurnacite' are smokeless types while other brands are made from lignite, peat or housecoal.

DO NOT BURN...

DUSTY MATERIALS like sawdust, can burn far too violently, even explode. **PETROLEUM COKE** sold as 'Petcoke', 'Longbeach' and other names, is made from oil, is very high in acid will rapidly degrade interior parts. **HOUSEHOLD WASTES** Some plastics give off toxic fumes when burned and remember that batteries and aerosols explode! The stove is not an incinerator. **HOUSECOAL** or **BITUMINOUS COAL** (not smokeless) makes tarry smoke and flammable gas which make it difficult to control and risk explosions. It is cheap, but rarely represents value for money. **NEVER** use liquid fuels in any form.

PROBLEMS?

Problems like those listed here are usually due to some difficulty with the installation, chimney or fuels, so please check back through this leaflet carefully. If necessary seek specialist advice.

SMOKE FROM THE CHIMNEY A little smoke will be emitted from the chimney when the fire is cold. Use only VERY dry wood or smokeless fuels. Make sure the 'smoke stop' is in place.

DAMAGED LINERS The BFM stove gets very, very hot inside, it is quite usual for the replaceable liners to crack or craze. They need only be replaced when they have almost completely disintegrated. Help them last longer by using only very dry fuel.

POOR HEAT OUTPUT: A stove can heat a typical room of *about* 12m³ volume for each kW of output, so a 5kW model can heat up to (12 x 5) 63m³, a room of about 5m square. The actual size depends on the insulation and air-change ratio of the room. To attempt to heat a larger room will result in excessive fuel consumption and damaging overheating.

LACK OF CONTROLLABILITY Wood and some other fuels may burn

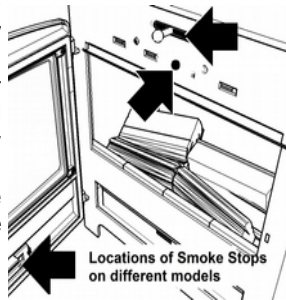
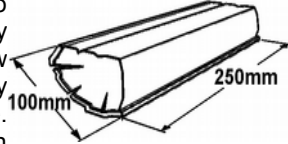
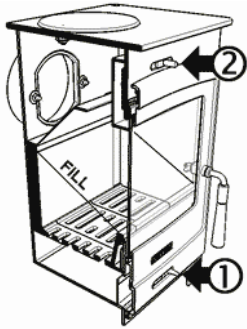

excessively until the gases in them have been used up. You can reduce this effect by making sure that the fire is set to 'low' for a while before refuelling and checking that the door seals fully. For stoves with a Smoke Stop - adjust the heat output by how much fuel you put on, as well as by using the controls.

DIFFICULTY BURNING FOR EXTENDED PERIODS If the fire goes out with fuel still in the firebox, try leaving the air controls open a little more. Check that the door seals are sound and that there are no cracks or gaps anywhere in the flue. For longest burning, we recommend hard fuels such as anthracite. Burn times will be much shorter when the 'smoke stop' is fitted.

THE DOOR CATCH may need adjusting as the rope seal 'beds down'. Simply loosen the screw and move the tapered pin as shown. Re-tighten the screw.

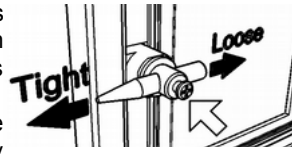

CONDENSATION onto cool surfaces inside the stove can be severe if fuel is in any way damp. Use only very dry fuel.

OVER-FIRING: It is possible to leave the fire too long with the controls set too high leading to 'over firing', seen as glowing metal parts, excessive chimney temperature and risk of parts failing or chimney fires. Always set controls to the lowest practical setting. A chimney thermometer, from your local stove shop, can help.

SMOKE COMING INTO ROOM Fumes are poisonous- smoke emission must NEVER be tolerated, causes might be:

NEW STOVE: There is often a smell and sometimes visible fumes as the paint cures. This normally stops after an hour or so.

INADEQUATE SEALS: Are all flue pipes and connectors *absolutely* gas-tight? Even the tiniest crack or gap can spoil the draught. Does an inset appliances fully seal against the fireplace?

BLOCKED THROAT PLATE: Has soot and ash collected on the 'throat plate' above the inner back part of the firebox?

UNSUITABLE, BLOCKED OR UN-SWEPT CHIMNEY: The first requirement for correct operation is a sound chimney. Check the requirements earlier in this document and in any case of doubt engage a professional sweep or chimney engineer.

POOR AIR SUPPLY: Lack of air to the fire is a common cause of smoking and poor performance. Air supply problems may be worse in

certain wind conditions (often incorrectly ascribed to 'downdraught', which is in fact very rare), where air can be sucked out of the room. The answer is to fit an air vent, as near to the fire as possible, facing into the usual wind direction.

DOWNDRAUGHT: Wind can blow down a chimney if there is something higher nearby such as a tree, hill or high building. Fitting an anti-downdraught cowl to the chimney top can cure this. Types which cannot be swept through are not recommended.

POOR CHIMNEY DRAUGHT- Draught in use MUST be 12Pa.

CHIMNEY FIRE: In the rare event of deposits inside the chimney igniting (roaring sound + dense smoke, sparks from chimney) immediately close the door, shut all air controls and call the fire brigade. Prevent fires by using *very dry fuel* and having your chimney swept regularly.

MAINTENANCE

MONTHLY- With the fire cold, remove, clean and refit the throat (or 'baffle') plate below the flue outlet. Check that the flue is clear and unblocked, and that the door seals are sound.

ANNUALLY- SWEEP THE CHIMNEY The entire length of the chimney from stove to outlet should be swept annually, more often if smoky fuels are used.

NEW PARTS Your stove has been extensively tested for safety - please don't try to modify it and always obtain genuine spare parts.

SURFACE FINISH Wipe the stove body with a slightly damp cloth when cool. Don't use aerosol spray or wax near the hot fire - they can ignite. Painted steel parts can be refurbished using special spray paint. Coloured doors are traditional hand-applied vitreous enamel - it will have small surface imperfections and, while virtually immune from fading, rust and scratches, it can chip.

Your stove generates **VERY** high temperatures. Eventually the internal parts will require replacement. Help parts to last by:

- Using only recommend, *very dry*, fuels.
- Emptying the ash very regularly when using mineral fuel -never allow it to touch the underside of the grate.
- Cleaning the throat plate regularly.
- Avoiding 'over-firing'

PARTS AND ACCESSORIES

BFM spares Tel. 01782 339034 Fax 01782 339028

Which BFM stove have I got? The Inset Models fits into a wall or fireplace. Freestanding models are approximately 390mm wide (No1), 500mm (No2) or 610mm (No3). Steel models have a smooth body finish, cast iron ones have a decorated surface.

Boost Boiler (1)	For free-standing models. Specify 1, 2 or 3
Throat plate (2)	Specify 1, 2 or 3
Liners (3, 4)	Specify 1, 2 or 3 or Glass-front Inset
Cast Grate (5)	For all models with cast-iron grates
Alloy Grate (5a)	Specify outer (black steel, 4-hole) or inner (chromium, 6-hole) and front bar (15) size 1,2 or 3
Riddling Grate (5b)	Cast-Iron models, specify No 1, 2 or 3 (Not shown)
Glass panel (6)	Steel or square-door-cast models specify No1, 2 or 3 Cast-Iron curved door specify No1 or No2 Glass-Front models specify No1 or No2, door or top Curved Stove Inset with cast door, specify window size 2 Inset with glass door
Rope seal kit (7)	All models
Ashpan (10)	Specify size 1, 2 or 3
Door catch pin (11)	All models
Door handle (12)	A: Magnetic black phenol B: Traditional Handle C: Contemporary Handle
Ashpan handle (13)	All models
Legs (14)	150mm or 300mm
Hinge Pin (15)	All models
Heat Shield (18)	All freestanding models
Fire Reducer (19)	All models (pair)

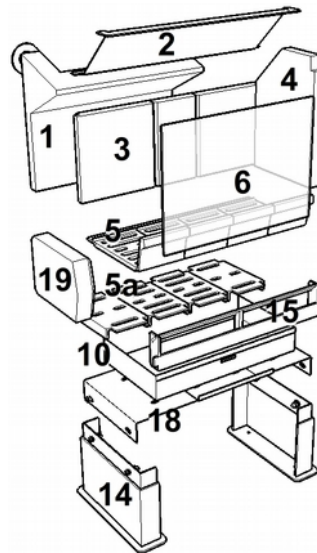

Position of Replaceable Parts
(Appearance will vary with model)

Accessories: Touch-up paint black or charcoal - Safe air supply kit - Canopy - Window Trellis - heat-resistant glove **Also Available:** Marine model to Boat Safety Standards - 16kW Central Heating stove with automatic control - Wood-only stoves - Gas stoves.

BFM Europe
BRITISH FIRE MANUFACTURERS

MADE IN ENGLAND
Trentham Lakes, Stoke on Trent, Staffordshire, England ST4 4TJ
www.bfm-europe.com Tel 01782 339000 Fax 01782 339009



The BFM stove designs are registered at the UK Patent Office and protected by Copyright © and UK Design Right, Glyn Hughes 2006-2017. Certain parts are UK Patent Applied For. This document printed 28/11/2017. We are always striving to improve these products and may change their specification without notice.